

NEEDLE BAR HEIGHT

Needle bar height

[Diagnosis]

1. Measure the distance (A) between the rotary hook center and the needle point when the needle bar is brought to the lower dead point by turning the hand wheel counterclockwise. (Fig. 1)
2. Measure the distance (B) between the upper end of needle hole and the upper end of rotary hook blade point when the rotary hook blade point is aligned with the needle center by turning the hand wheel further.

[Standard]

A = 8.0 ± 0.2 mm

B (Reference) = 1.0 ± 0.2 mm (Fig. 1)

* Make adjustment if the diagnosis result fails to meet the standard.

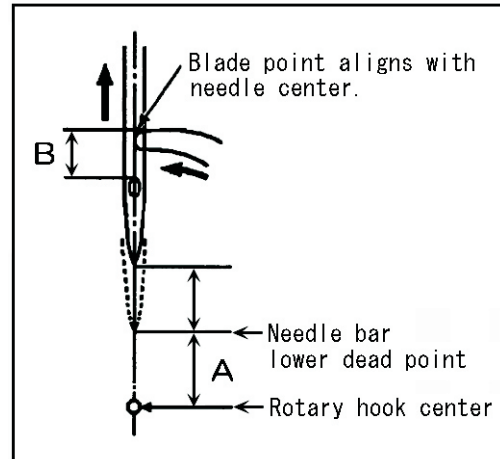

Fig.1

[Adjustment]

1. Remove the lower cover.
(See:page.61 and after)
2. Loosen the needle bar connecting stud set screw.(Fig. 2)
3. Adjust the needle bar height.(Fig. 1)
4. Tighten the needle bar connecting stud set screw.

[Note]

- ? Replace the needle to see if it can be exchanged surely.
- ? If needle replacement is not possible, adjust the distance between the upper dead point stopper lower end and the needle bar connecting stud upper end to 4.5 mm.(Fig. 2)

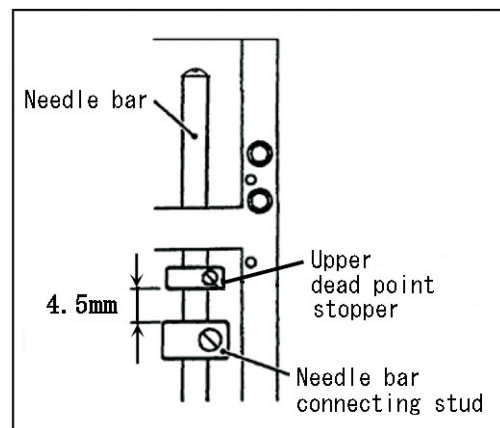

Fig.2

* Repeat the adjustment till the standard is met.